

SALES DRAWING SALES DRAWING

SALES DRAWING SALES DRAWING

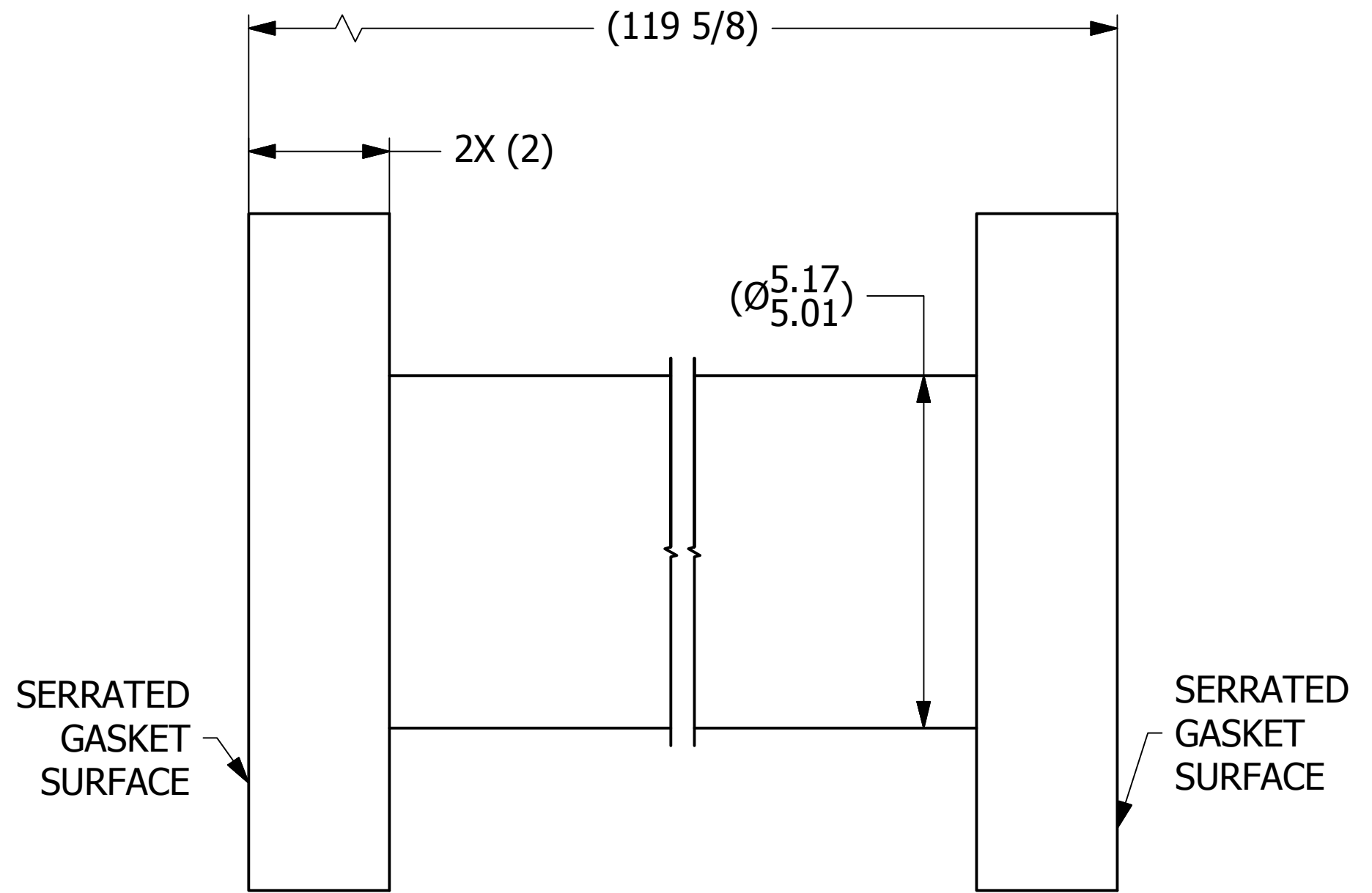

NOTE:
 SOLD TO WORLEY WELDING ONLY.

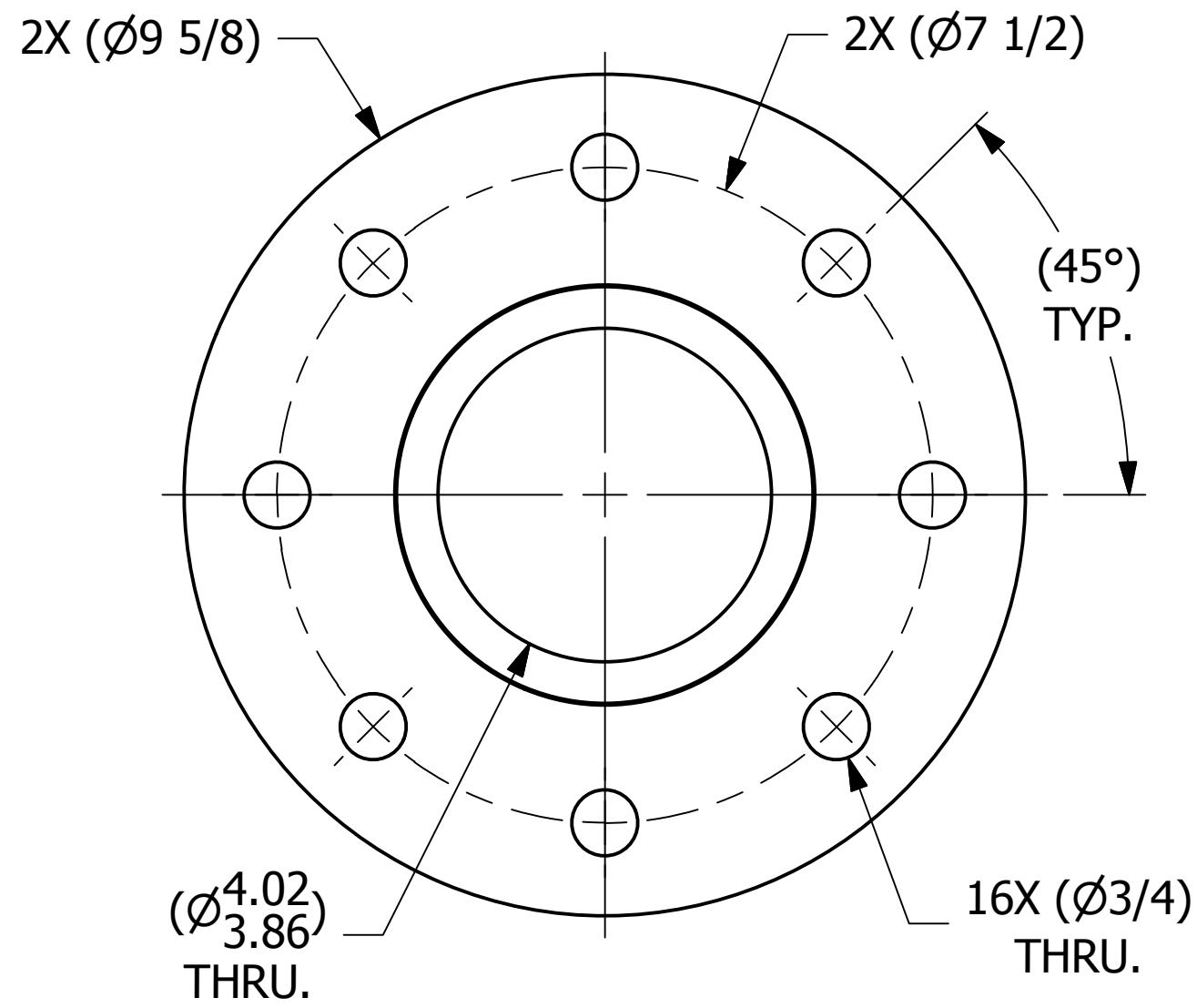
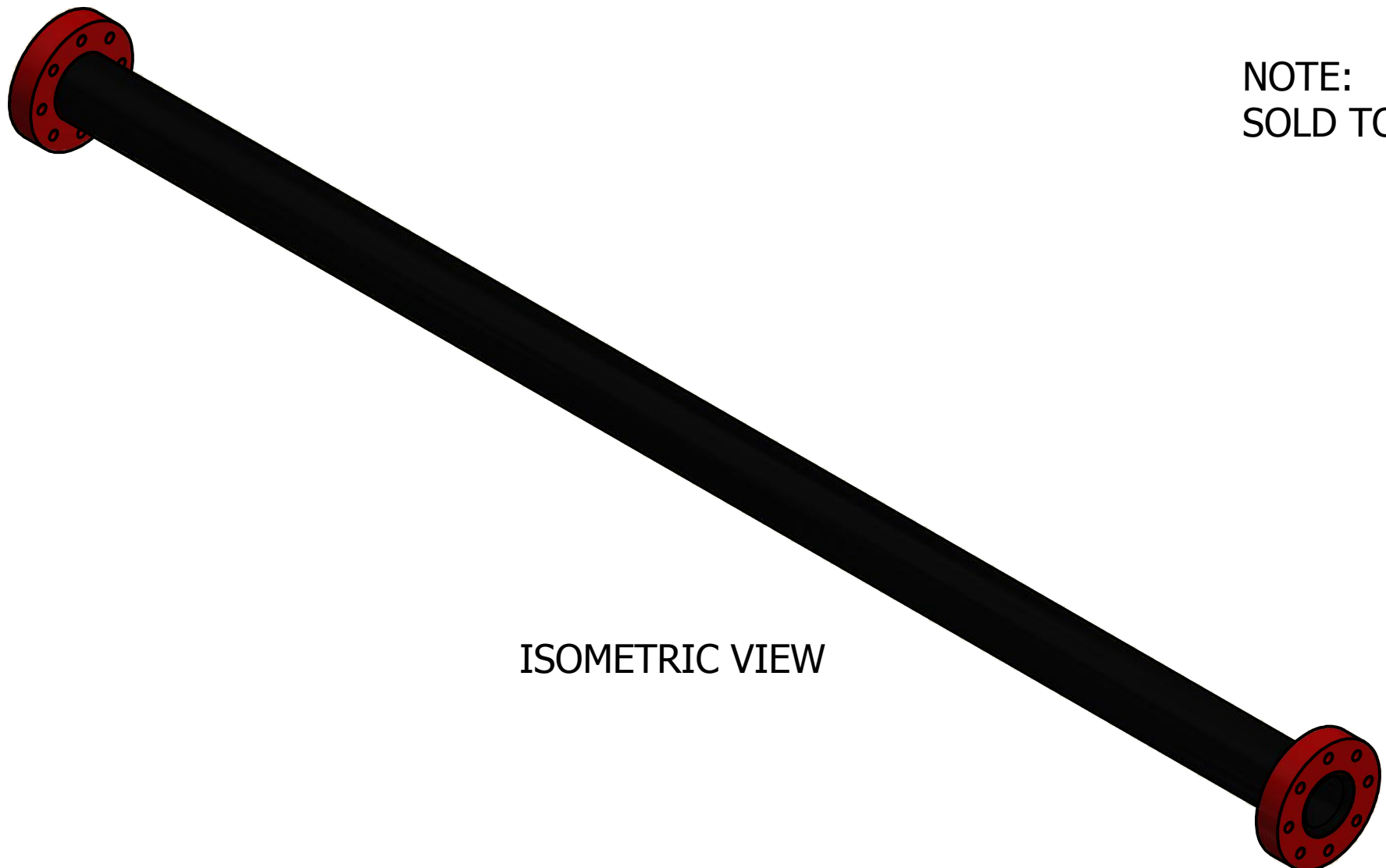

C	TAK	8-30-17	ADDED DSS 3 NOTE, REPLACED QAP5F-1 W/ QAP5A-1
B	GDS	7-27-11	ADDED MARKING PRESSURE NOTE
A	REH	10-22-10	ADDED PART TO SYSTEM
REV	BY	DATE	DESCRIPTION

UNLESS OTHERWISE SPECIFIED DIMENSIONAL TOLERANCES FRACTIONAL: ±1/16 X.XX: ±.03 X.XXX: ±.015 ANGLE: ±1° DEBURR ALL SHARP EDGES. ALL MACHINED SURFACES TO HAVE A 125 RMS FINISH UNLESS NOTED OTHERWISE. THIRD ANGLE PROJECTION	DRAWN BY:	REH
	CHECKED BY:	VD
	PROTOTYPE BY:	REH
	PROTOTYPE DATE:	10/13/2010
	APPROVED FOR PRODUCTION BY:	VD
	PRODUCTION DATE:	10/22/2010

SALCO PRODUCTS, INC.		
PART NAME: PIPE SPOOL 4"		
MATERIAL: SALCO PE		
PROJECT #:	WAG0870	SHEET #: 1 OF 1
DRAWING #:	C29659	SCALE: 1:2
PART #:		HS4PS45120BK